

1 BUSBAR TRUNKING

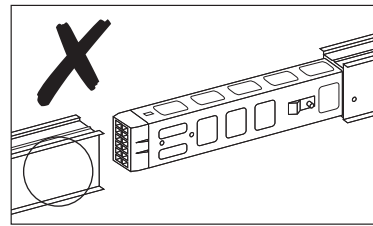

EEC360
 IP54 Trunking
 NOTE: To maintain IP54 rating, covers must be fitted to all unused outlets

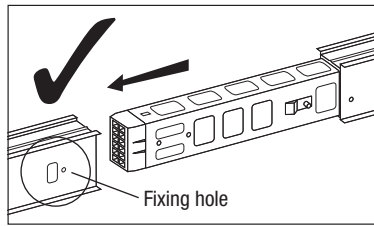
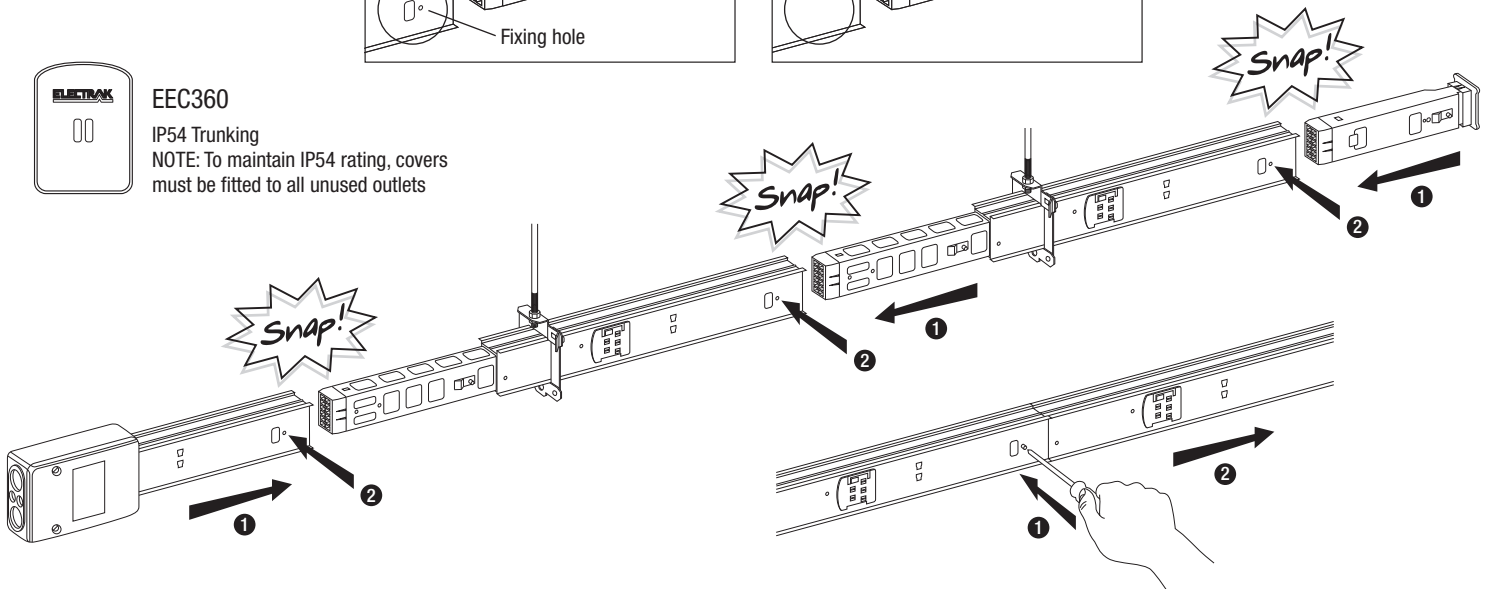

1. Calculate distance between fixing brackets.
2. Maximum fixing distance between brackets is not to exceed 4m.
3. If trunking is used to hang loads see loading charts.
4. Fix brackets to drop rods or surface, see mounting details.
5. Remove transit end caps from trunking.
6. Push fit feed unit onto first length of trunking.
7. Ensure fixing button is located into mating hole.
8. Place first length of trunking into fixing brackets and lock as shown on mounting details.
9. Place second length of trunking into fixing bracket.
10. Push fit second trunking length into first length of trunk until fixing button is located into mating hole.
11. Lock fixing brackets.
12. Continue as above until last length of trunking is in place.
13. At end of run fit the end stop that is supplied with the feed unit.
14. Ensure all fixing bracket locking arms are fully pushed home.

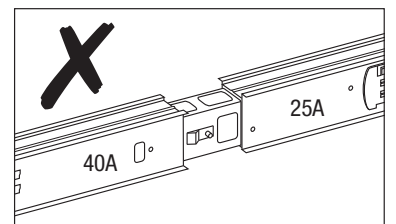
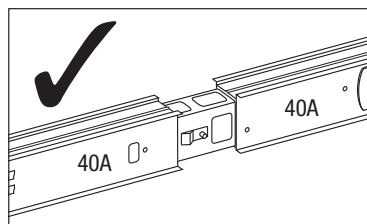
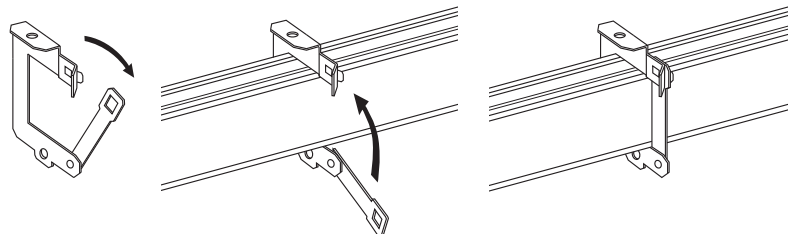

2 SUSPENDED FIXING BRACKET

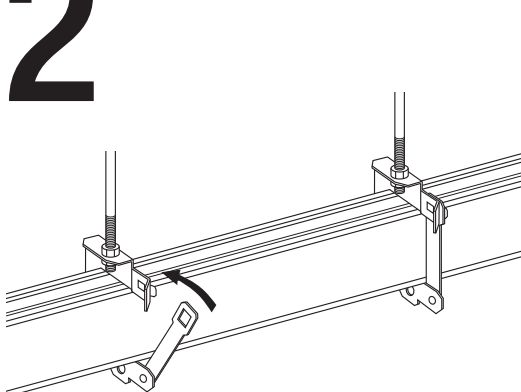

EEA308

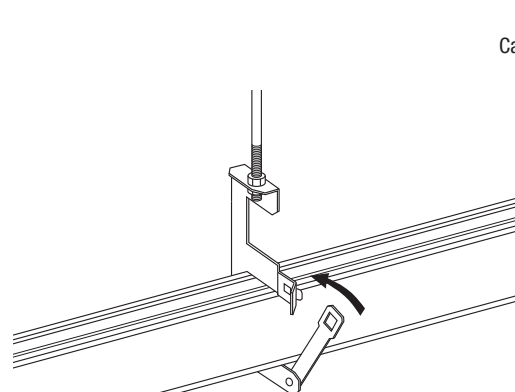
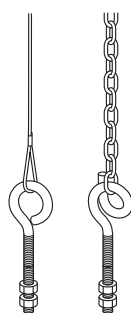

EEA312

Cable duct clips into bracket

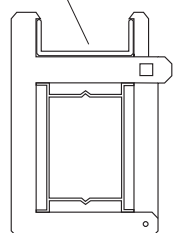

EEC352
 Cable duct bracket

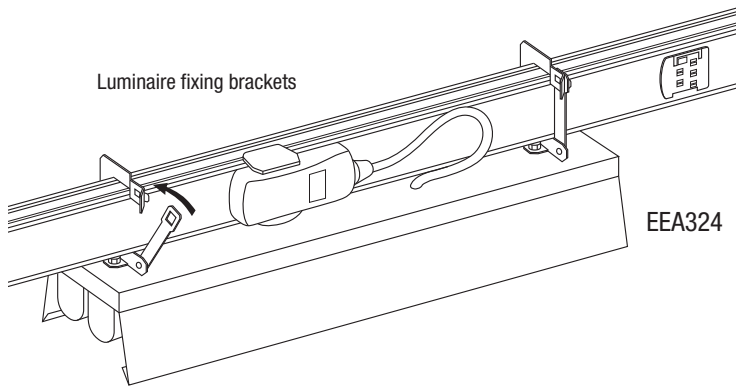

Maximum Loading for Suspended Busbar Trunking

Fixing distance in metres	1.5	2	2.5	3	3.5	4
Max. Point Load	20	17	13	12	9	8
Max. Distributed Load	33	28	22	20	15	12

Notes

- A. The guidelines are based on deflection 1/500.
- B. Suspension rods and fixings should be of a suitable size to carry the weight of both the track and suspended loads.
- C. Maximum busbar trunking weight 2Kg/m.

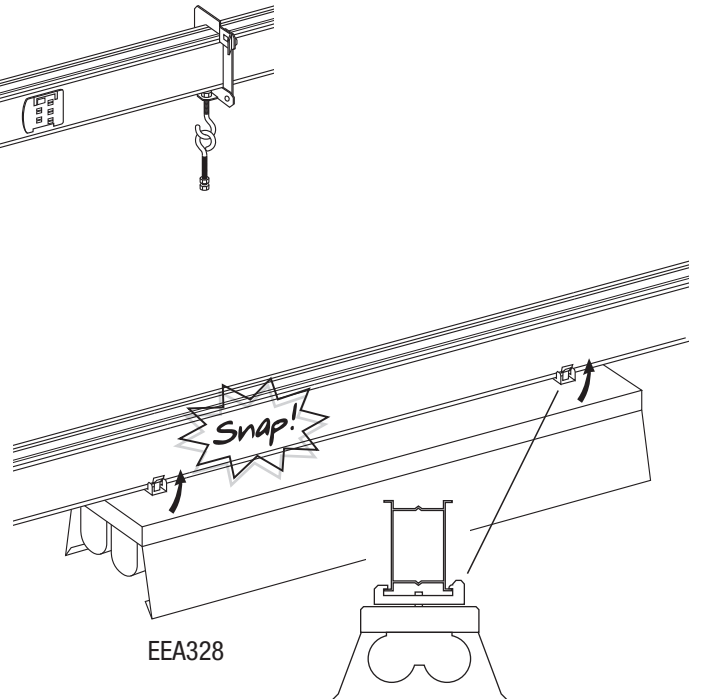
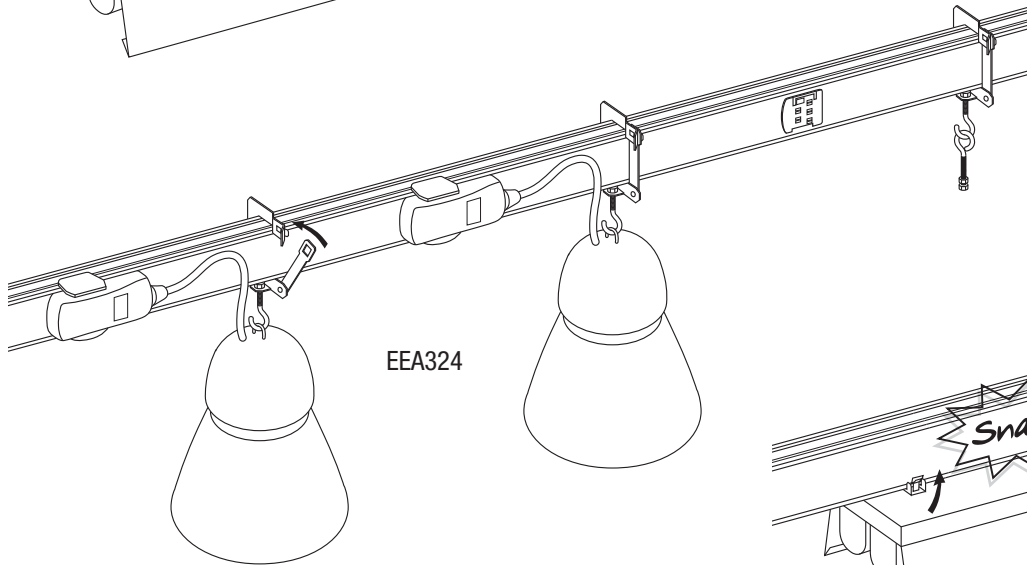

3 SURFACE MOUNTED FIXING BRACKET

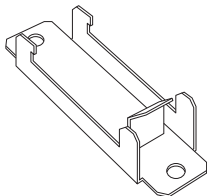

EEA304 57mm Edge Surface Fixing Bracket

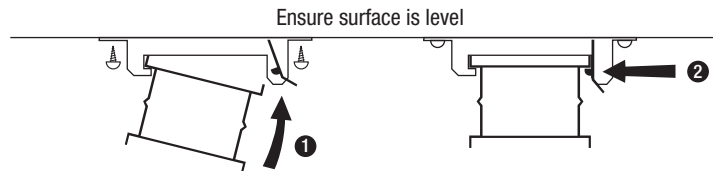

Screw fix through both fixing holes of surface fixing bracket to surface with No. 8 fixing screws.

Maximum Loading for Surface Mounted Busbar Trunking

Fixing distance in metres	1.5	2	2.5	3	3.5	4
Max. Point Load	10	6	4.5	4	3.5	3
Max. Distributed Load	16	10	7.5	7	6	5

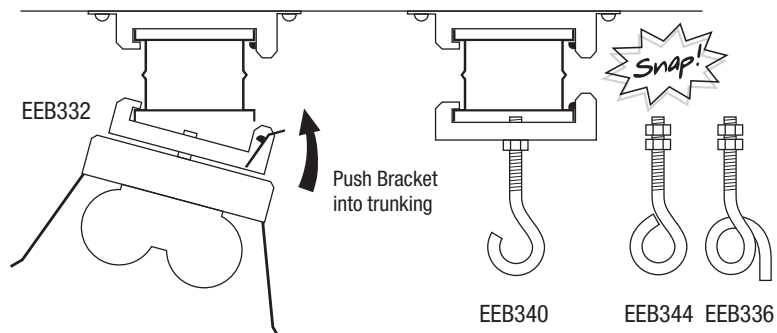

EEA328 45mm Edge Luminaire Fixing Bracket maximum load 5kg

EEA332 57mm Edge Luminaire Fixing Bracket maximum load 5kg

Ensure all fixing brackets are fully pushed home.

4

FEED UNITS

25A rated - max. conductor size 6mm²
 40A rated - max. conductor size 16mm²
 Feed units have cable terminals on both sides for double sided trunking and use both 25mm knockouts.

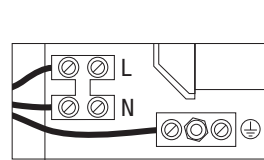
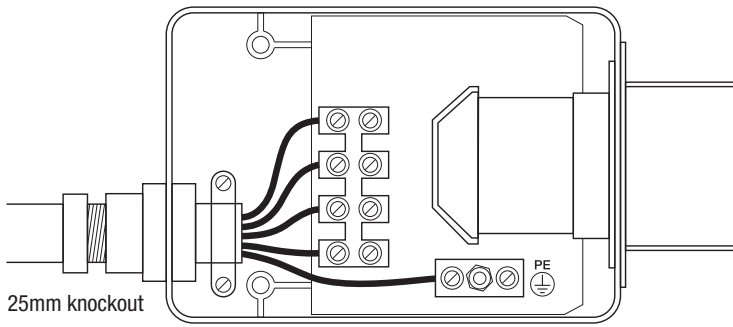

Electrak 30, 2P+E

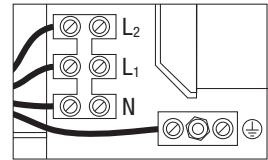

Electrak 31, 3P+E

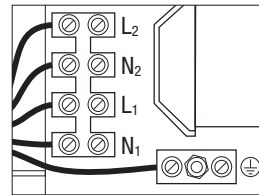

Electrak 32, 4P+E

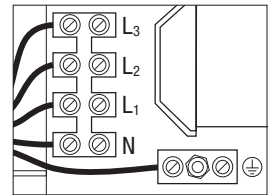

Electrak 33, 4P+E

5

TAP OFFS

Tap-off insertion

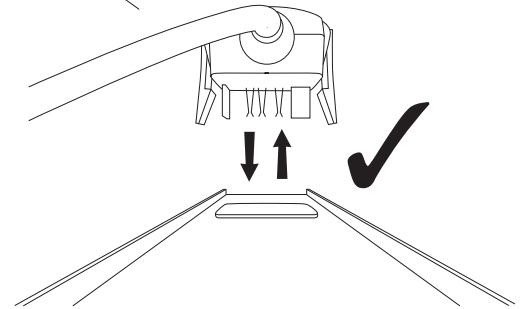
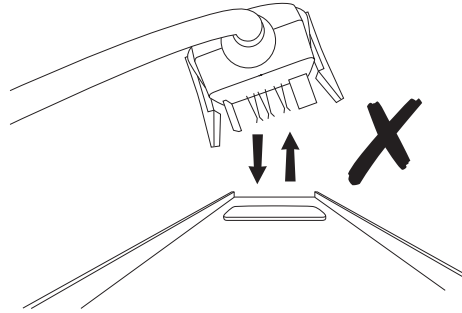
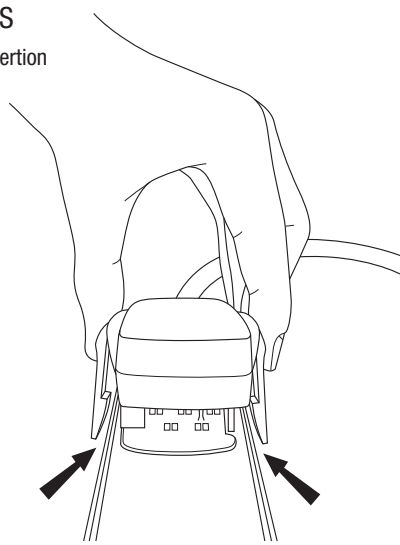

Phase selectable tap-off

Phase is denoted in tap-off base

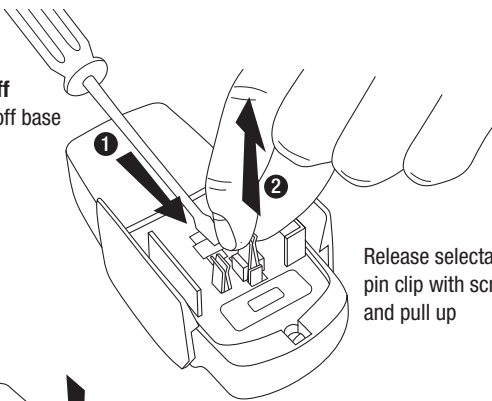

Release selectable pin clip with screwdriver and pull up

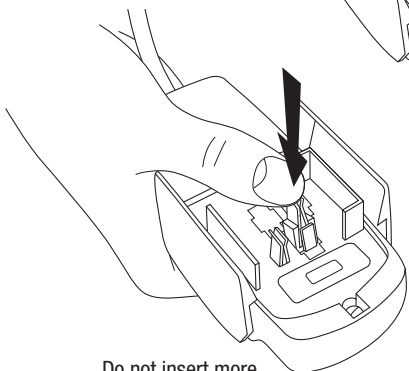

Do not insert more than one selectable pin clip

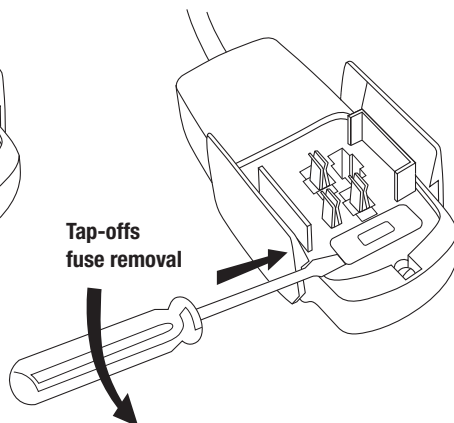

IMPORTANT WARNINGS

System ratings and types MUST NOT be interchanged.

A. TECHNICAL SPECIFICATION

See technical data sheet C4 for design data.

Remain in Light

B. ISOLATION

Isolate the circuit supply wiring at the distribution point.

C. INSTALLATION AND TESTING

The system should be installed, tested and maintained by a qualified electrician or other competent person in accordance with BS7671:2008 (IEE Wiring Regulations) and/or relevant local regulations.

D. PROTECTION

The circuit must be protected by a suitably rated fuse or circuit breaker in accordance with BS7671:2008 (IEE Wiring Regulations).

E. DIFFERENT PHASES

Where track runs can be reached simultaneously and are supplied by different phases the system must carry warning notices as required by Reg. 514.10.1 of BS7671:2008 (IEE Wiring Regulations).



A Group brand | **legrand**

FOR INFORMATION ON OTHER FIXING METHODS, ADDITIONAL INSTALLATION SHEETS OR TECHNICAL HELP CONTACT ELECTRAX.

Tel: 01207 503400 | Fax: 01207 501799 | Email: sales@electrak.co.uk | Web: www.electrak.co.uk

Electrak

Because of our policy of continuous improvement, Electrak reserve the right to change product specification without notice