

**CATALOGUE NUMBERS:
DZ1210 & DZ1230**

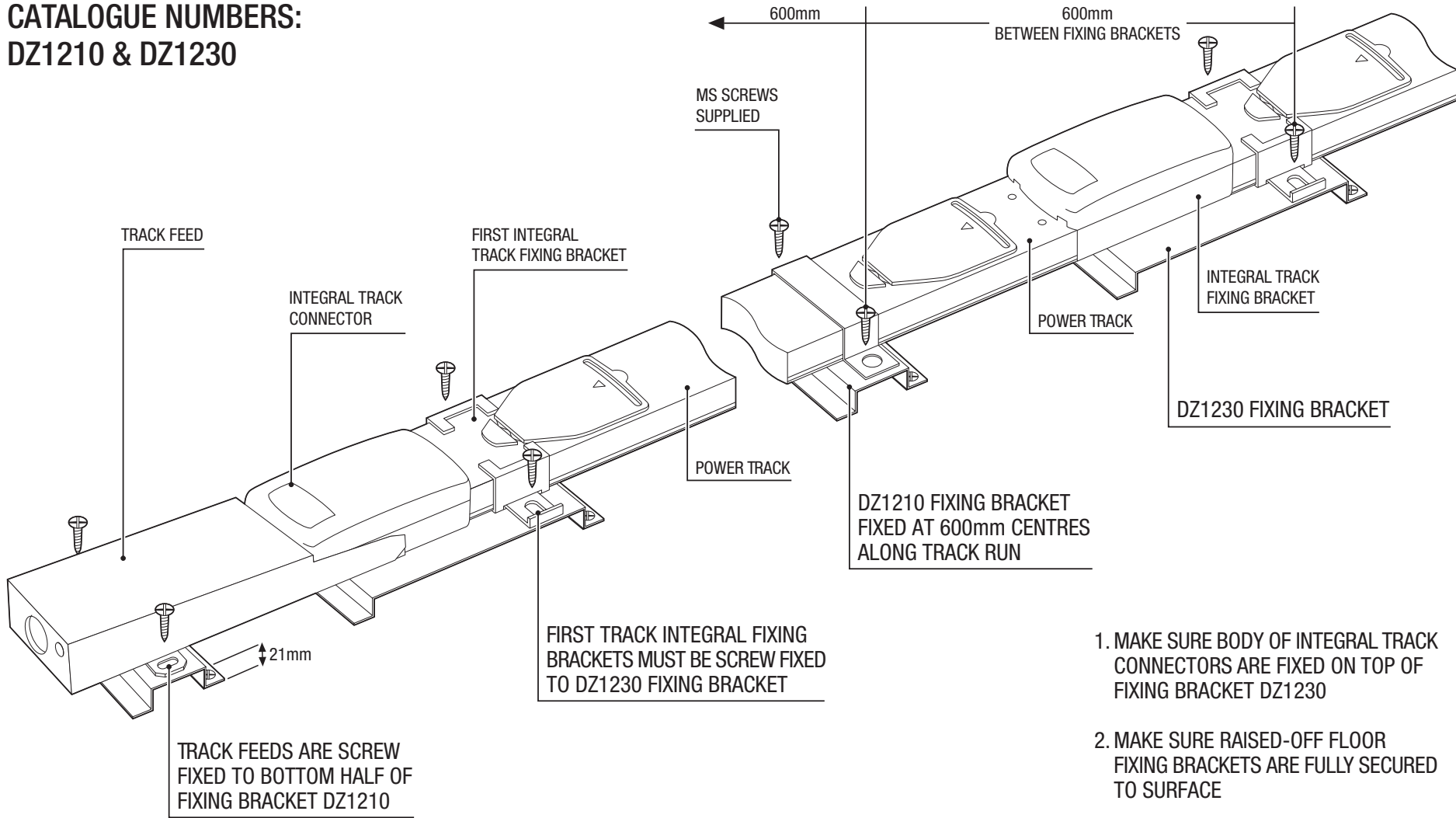

BRACKET FIXING DIMENSIONS TO SURFACE

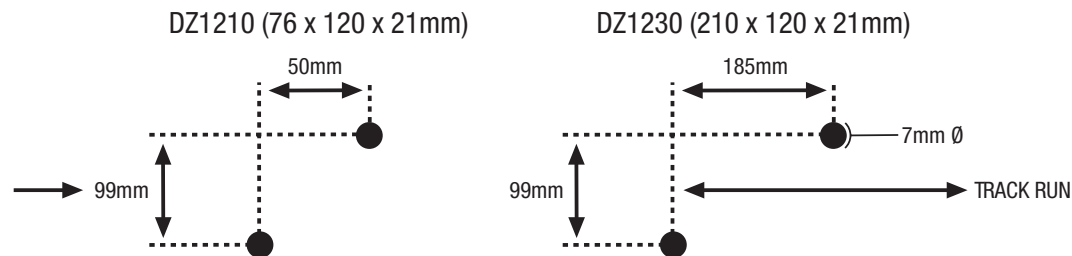

1. MAKE SURE BODY OF INTEGRAL TRACK CONNECTORS ARE FIXED ON TOP OF FIXING BRACKET DZ1230
2. MAKE SURE RAISED-OFF FLOOR FIXING BRACKETS ARE FULLY SECURED TO SURFACE
3. TOTAL HEIGHT OF POWER TRACK, TAP OFF AND RAISED OFF FLOOR BRACKET = **68mm**

Electrak International Ltd

Tel: 01207 503400
 Fax: 01207 501799
 Email: sales@electrak.co.uk
 Web: www.electrak.co.uk

Because of our policy of continuous improvement, Electrak reserve the right to change product specification without notice

**Electrak 24, 25, 26, 27
Power Track Systems
Raised-off Floor Fixing Brackets
Installation Sheet B9**

