

Electrak[®] power track underfloor distribution system

Electrak has led the power distribution market for cavity floor solutions since 1984 when it launched the first small power track system. With minimal parts and push-fit assembly, this flexible system is easy to install and minimises disruption as office layouts evolve.

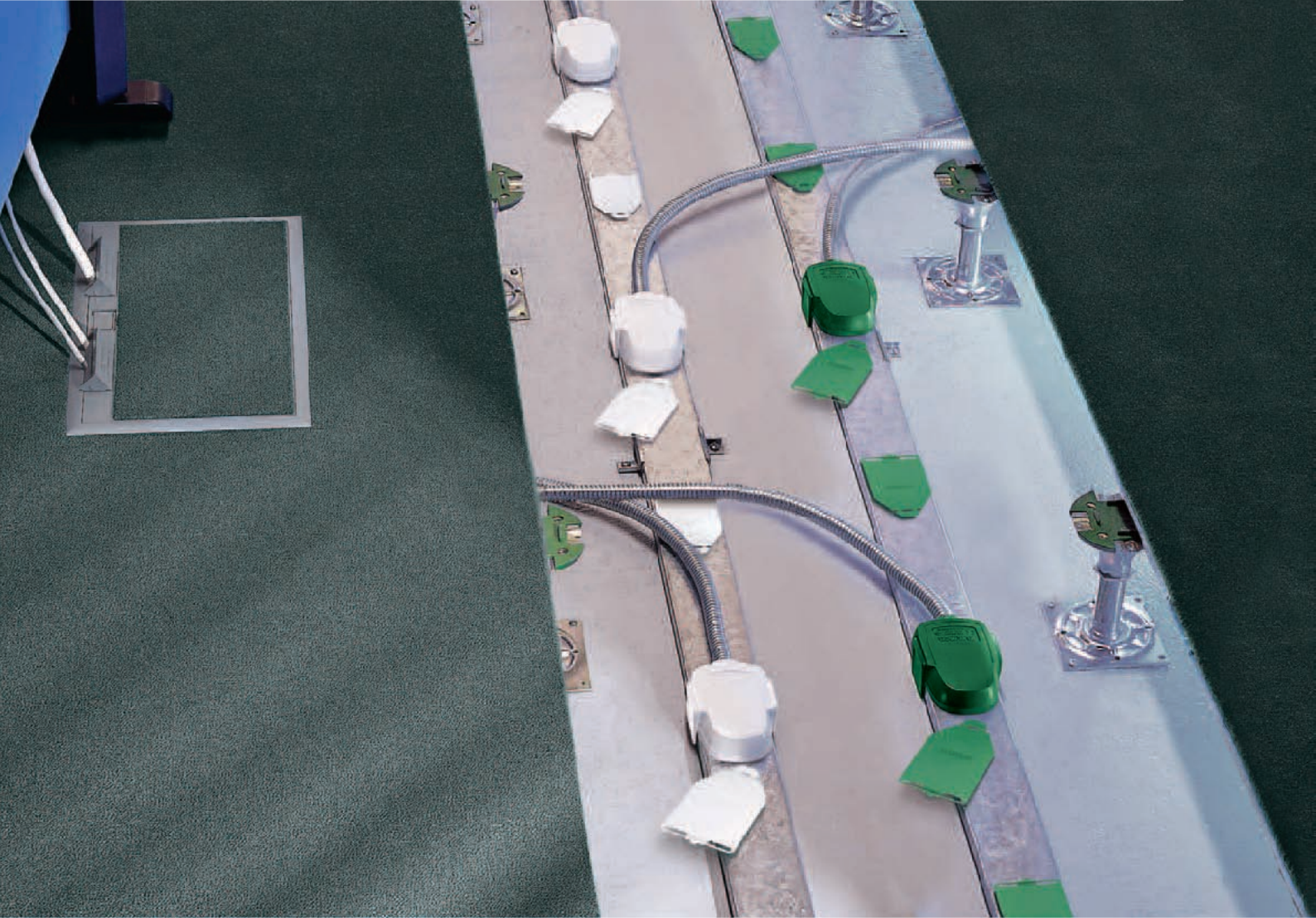

DESIGN AND INSTALLATION

The system consists of continuous lengths of track (generally arranged in parallel format) which are fed from the distribution board via track feed boxes and can be installed in floor voids as low as 48 mm.

Track lengths fit together using integral track connectors for quick assembly with access to power via tap-offs from the shuttered outlets.



Intertek



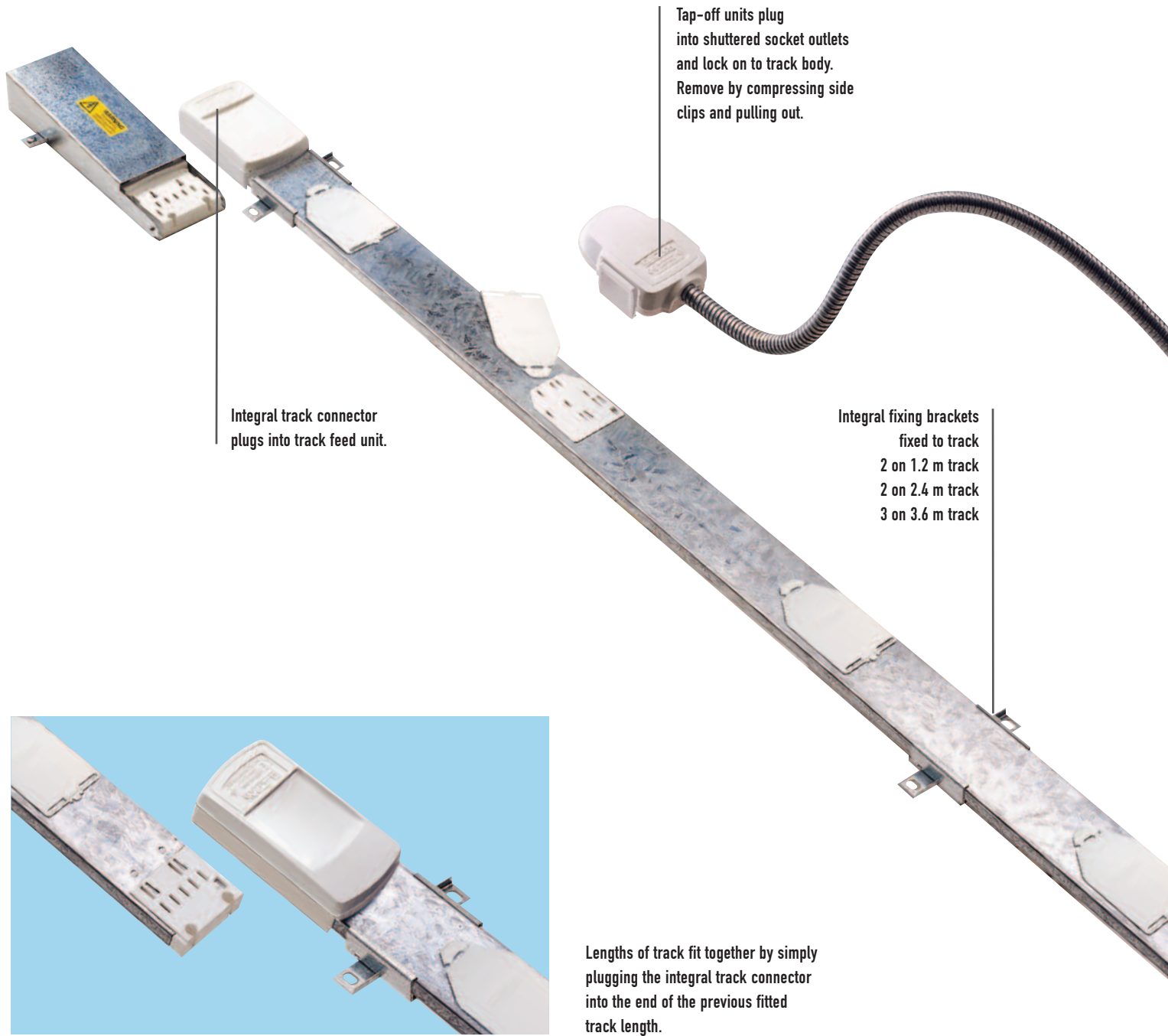





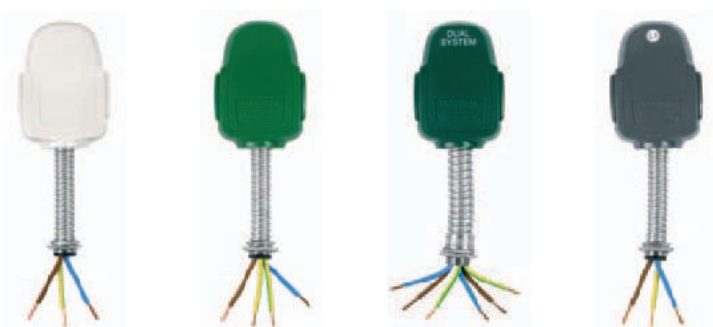



EXTENDED RANGE

Available in four versions to meet all power requirements in today's modern offices... standard, low noise / clean earth, dual circuit and three phase.



Electrak® power track systems

	Description	Length (m)	
Track lengths with 300 mm socket centres			
	4 sockets	1-2	
	8 sockets	2-4	
	12 sockets	3-6	
Track feed			
		–	
Flexible interlink / corner			
	Excluding cables and conduit	–	
	Flexible metal conduit	1-2	
	Flexible metal conduit	2-4	
Standard tap-off			
	32 A unfused 16 mm Ø L, N, PE	3 5	
	13 A fused 16 mm Ø L, N, PE	3 5	
	13 A 543-7 unfused 16 mm Ø L, N, PE	3 5	
Low noise / clean earth tap-off			
	32 A unfused 16 mm Ø CE, L, N, PE	3 5	
	13 A fused 16 mm Ø CE, L, N, PE	3 5	
	13 A 543-7 unfused 16 mm Ø CE, L, N, PE	3 5	
Dual circuit tap-off			
	32 A unfused 20 mm Ø CE, L1, N1 L2, N2, PE	3 5	
3 phase tap-off			
	32 A 415 V 3 phase 20 mm Ø L1, L2, L3, N, PE	3 5	
	32 A L1 unfused reconfigurable live pin 16 mm Ø L1, N, PE	3 5	
	32 A L2 unfused reconfigurable live pin 16 mm Ø L1, N, PE	3 5	
	32 A L3 unfused reconfigurable live pin 16 mm Ø L1, N, PE	3 5	
	Tap-off, track feed and track connector key code		

	 ELECTRAK 24 Standard system (white)	 ELECTRAK 25 Low noise / clean earth system (light green)	 ELECTRAK 26 Dual circuit system (dark green)	 ELECTRAK 27 3 phase system (grey)
	DA1123	JA2123	KA3123	NA4123
	DA1243	JA2243	KA3243	NA4243
	DA1363	JA2363	KA3363	NA4363
	DF1010	JF2010	KF3010	NF4010
	DW1000	JW2000	KW3000	NW4000
	DW1010	JW2010	KW3010	NW4010
	DW1020	JW2020	KW3020	NW4020
	DP1332	–	DP1332	–
	DP1532	–	DP1532	–
	DP1313	–	DP1313	–
	DP1513	–	DP1513	–
	DP1327	–	DP1327	–
	DP1527	–	DP1527	–
	–	JP2332	JP2332	–
	–	JP2532	JP2532	–
	–	JP2313	JP2313	–
	–	JP2513	JP2513	–
	–	JP2327	JP2327	–
	–	JP2527	JP2527	–
	–	–	KP3328	–
	–	–	KP3528	–
	–	–	–	NZ4331
	–	–	–	NZ4531
	–	–	–	NP4332 ⁽¹⁾
	–	–	–	NP4532 ⁽¹⁾
	–	–	–	NP4302 ⁽¹⁾
	–	–	–	NP4502 ⁽¹⁾
	–	–	–	NP4303 ⁽¹⁾
	–	–	–	NP4503 ⁽¹⁾
				

(1) All NP tap-offs are reconfigurable between L1, L2 or L3 for 3 phase track

Electrak[®] 24 power track system

standard system (white)



[Selection chart \(p. 16-17\)](#)
[Dimensions and technical information \(p. 22-25\)](#)

Approved to ASTA Standard 138 and ISO 9001 : 2008
 Conforms to BS EN 60439-2 : 2008. Fully complies with the requirements of BS 7671 : 2008 IEE Wiring Regulations
 A compact system that can be installed in floor voids as low as 48 mm

Pack	Cat. Nos.	Track system components
		Electrak 24 standard track lengths Track lengths fit together using the integral connectors on each length Track lengths should always be secured using the integral floor fixing brackets 300 mm socket centres
1	DA1123	1.2 m, 4 sockets, 2 floor fixing brackets
1	DA1243	2.4 m, 8 sockets, 2 floor fixing brackets
1	DA1363	3.6 m, 12 sockets, 3 floor fixing brackets
		Track feed unit
1	DF1010	With one 25 mm diameter hole suitable for MICC, armoured cables or single core cables in conduit
		Flexible interlinks Can be used to overcome obstructions or as corners where required
1	DW1000	Excluding cables and conduit
1	DW1010	1.2 m flexible metal conduit
1	DW1020	2.4 m flexible metal conduit
		Special fixing brackets Required when track is raised off surface level Brackets raise track by 21 mm and should be spaced 600 mm apart
1	DZ1210	For fitting under track body and track feed
1	DZ1230	For fitting under integral track connectors

Pack	Cat. Nos.	Tap-off units
		Tap-off length is determined by the cable and not the conduit length, e.g. a 3 m tap-off has 3 m of cable and 2.8 m of flexible metal conduit ⁽¹⁾ Tap-off units in excess of 3 m should only be used if they contain a fuse or if the power track is protected by a 32 A rated protective device
		32 A unfused 16 mm Ø, L, N, PE
1	DP1332	3 m
1	DP1532	5 m
		13 A fused 16 mm Ø, L, N, PE
1	DP1313	3 m
1	DP1513	5 m
		13 A 543.7 fused - high integrity 16 mm Ø, L, N, PE
1	DP1327	3 m
1	DP1527	5 m

(1) Tap-offs are supplied as standard with flexible metal conduit
 For alternative wiring solutions, contact us on +44 (0) 845 600 6266

Electrak® 25 power track system

low noise / clean earth system (light green)

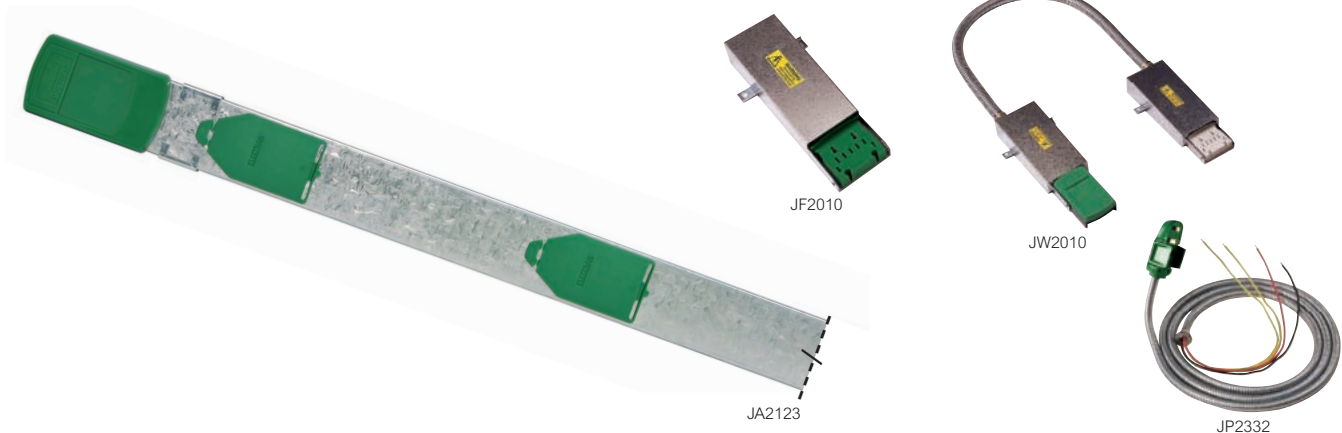

 [Selection chart \(p. 16-17\)](#)
[Dimensions and technical information \(p. 22-25\)](#)

Approved to ASTA Standard 138 and ISO 9001 : 2008
 Conforms to BS EN 60439-2 : 2008. Fully complies with the requirements of BS 7671 : 2008 IEE Wiring Regulations
 A compact system that can be installed in floor voids as low as 48 mm

Pack	Cat. Nos.	Track system components
		Electrak 25 low noise / clean earth track lengths Track lengths fit together using the integral connectors on each length Track lengths should always be secured using the integral floor fixing brackets 300 mm socket centres
1	JA2123	1.2 m, 4 sockets, 2 floor fixing brackets
1	JA2243	2.4 m, 8 sockets, 2 floor fixing brackets
1	JA2363	3.6 m, 12 sockets, 3 floor fixing brackets
		Track feed unit
1	JF2010	With one 25 mm diameter hole suitable for MICC, armoured cables or single core cables in conduit
		Flexible interlinks Can be used to overcome obstructions or as corners where required
1	JW2000	Excluding cables and conduit
1	JW2010	1.2 m flexible metal conduit
1	JW2020	2.4 m flexible metal conduit
		Special fixing brackets Required when track is raised off surface level Brackets raise track by 21 mm and should be spaced 600 mm apart
1	DZ1210	For fitting under track body and track feed
1	DZ1230	For fitting under integral track connectors

Pack	Cat. Nos.	Tap-off units
		Tap-off length is determined by the cable and not the conduit length, e.g. a 3 m tap-off has 3 m of cable and 2.8 m of flexible metal conduit ⁽¹⁾ Tap-off units in excess of 3 m should only be used if they contain a fuse or if the power track is protected by a 32 A rated protective device
		32 A unfused 16 mm Ø, CE, L, N, PE
1	JP2332	3 m
1	JP2532	5 m
		13 A fused 16 mm Ø, CE, L, N, PE
1	JP2313	3 m
1	JP2513	5 m
		13 A 543.7 fused - high integrity 20 mm Ø, CE, L, N, PE
1	JP2327	3 m
1	JP2527	5 m

(1) Tap-offs are supplied as standard with flexible metal conduit
 For alternative wiring solutions, contact us on +44 (0) 845 600 6266

Electrak[®] 26 power track system

dual circuit system (dark green)



Selection chart (p. 16-17)
Dimensions and technical information (p. 22-25)

Approved to ASTA Standard 138 and ISO 9001 : 2008
Conforms to BS EN 60439-2 : 2008. Fully complies with the requirements of BS 7671 : 2008 IEE Wiring Regulations
A compact system that can be installed in floor voids as low as 48 mm

Pack	Cat. Nos.	Track system components
		The dual power track system has both standard and low noise / clean earth systems incorporated
		Electrak 26 dual circuit track lengths
		Track lengths fit together using the integral connectors on each length
		Track lengths should always be secured using the integral floor fixing brackets
		300 mm socket centres
1	KA3123	1.2 m, 4 sockets, 2 floor fixing brackets
1	KA3243	2.4 m, 8 sockets, 2 floor fixing brackets
1	KA3363	3.6 m, 12 sockets, 3 floor fixing brackets
		Track feed unit
1	KF3010	With one 25 mm diameter hole suitable for MICC, armoured cables or single core cables in conduit
		Flexible interlinks
		Can be used to overcome obstructions or as corners where required
1	KW3000	Excluding cables and conduit
1	KW3010	1.2 m flexible metal conduit
1	KW3020	2.4 m flexible metal conduit
		Special fixing brackets
		Required when track is raised off surface level
		Brackets raise track by 21 mm and should be spaced 600 mm apart
1	DZ1210	For fitting under track body and track feed
1	DZ1230	For fitting under integral track connectors

Pack	Cat. Nos.	Tap-off units
		Tap-off length is determined by the cable and not the conduit length, e.g. a 3 m tap-off has 3 m of cable and 2.8 m of flexible metal conduit ⁽¹⁾
		Tap-off units in excess of 3 m should only be used if they contain a fuse or if the power track is protected by a 32 A rated protective device
		Standard 32 A unfused
		16 mm Ø, L, N, PE
1	DP1332	3 m
1	DP1532	5 m
		Standard 13 A fused
		16 mm Ø, L, N, PE
1	DP1313	3 m
1	DP1513	5 m
		Standard 13 A 543.7 fused
		16 mm Ø, L, N, PE
1	DP1327	3 m
1	DP1527	5 m
		Low noise / clean earth 32 A unfused
		16 mm Ø, CE, L, N, PE
1	JP2332	3 m
1	JP2532	5 m
		Low noise / clean earth 13 A fused
		16 mm Ø, CE, L, N, PE
1	JP2313	3 m
1	JP2513	5 m
		Low noise / clean earth 13 A 543.7 fused
		20 mm Ø, CE, L, N, PE
1	JP2327	3 m
1	JP2527	5 m
		Dual circuit 32 A unfused
		20 mm Ø, CE, L1, N1, L2, N2, PE
1	KP3328	3 m
1	KP3528	5 m

(1) Tap-offs are supplied as standard with flexible metal conduit
For alternative wiring solutions, contact us on +44 (0) 845 600 6266

Electrak® 27 power track system

3 phase system (grey)



 [Selection chart \(p. 16-17\)](#)
[Dimensions and technical information \(p. 22-25\)](#)

Approved to ASTA Standard 138 and ISO 9001 : 2008
 Conforms to BS EN 60439-2 : 2008. Fully complies with the requirements of BS 7671 : 2008 IEE Wiring Regulations
 A compact system that can be installed in floor voids as low as 48 mm

Pack	Cat. Nos.	Track system components
		Electrak 27 3 phase track lengths Track lengths fit together using the integral connectors on each length Track lengths should always be secured using the integral floor fixing brackets 300 mm socket centres
1	NA4123	1.2 m, 4 sockets, 2 floor fixing brackets
1	NA4243	2.4 m, 8 sockets, 2 floor fixing brackets
1	NA4363	3.6 m, 12 sockets, 3 floor fixing brackets
		Track feed unit With one 25 mm diameter hole suitable for MICC, armoured cables or single core cables in conduit
1	NF4010	
		Flexible interlinks Can be used to overcome obstructions or as corners where required
1	NW4000	Excluding cables and conduit
1	NW4010	1.2 m flexible metal conduit
1	NW4020	2.4 m flexible metal conduit
		Special fixing brackets Required when track is raised off surface level Brackets raise track by 21 mm and should be spaced 600 mm apart
1	DZ1210	For fitting under track body and track feed
1	DZ1230	For fitting under integral track connectors

Pack	Cat. Nos.	Tap-off units
		Tap-off length is determined by the cable and not the conduit length, e.g. a 3 m tap-off has 3 m of cable and 2.8 m of flexible metal conduit ⁽¹⁾ Tap-off units in excess of 3 m should only be used if they contain a fuse or if the power track is protected by a 32 A rated protective device
		32 A 415 V 3 phase 20 mm Ø, L1, L2, L3, N, PE
1	NZ4331	3 m
1	NZ4531	5 m
		32 A L1⁽²⁾ unfused Unfused Reconfigurable live pin 16 mm Ø, L, N, PE
1	NP4332	3 m
1	NP4532	5 m
		32 A L2⁽²⁾ unfused Unfused Reconfigurable live pin 16 mm Ø, L, N, PE
1	NP4302	3 m
1	NP4502	5 m
		32 A L3⁽²⁾ unfused Unfused Reconfigurable live pin 16 mm Ø, L, N, PE
1	NP4303	3 m
1	NP4503	5 m

(1) Tap-offs are supplied as standard with flexible metal conduit
 For alternative wiring solutions, contact us on +44 (0) 845 600 6266
 (2) All NP tap-offs are reconfigurable between L1, L2, or L3 for 3 phase track

■ General installation notes

Electrak power track is a compact system that can be installed in floor voids as low as 48 mm

Track feed boxes are provided with one or two 25 mm diameter holes suitable for MICCC, armoured cables or single core cables in conduit. Track lengths connect together and to track feeds using the integral connectors on each length.

Track lengths should always be secured using the integral floor fixing brackets; three on the 3.6 m length and two on 2.4 m or 1.2 m lengths. Access to power is provided along the track length by simply plugging tap-off units into shuttered socket outlets. These tap-off units feed all types of conventional floor service outlet boxes or feed workstations directly through the floor via 4 mm² or 1.5 mm² insulated conductors contained in flexible metal or VO rated nylon conduit. When connecting tap-offs directly through the floor via grommet outlets to workstations care must be taken to ensure that the tap-off length is adequate.

The dual power track system has both standard and low noise / clean earth systems incorporated. As well as dual tap-offs, both standard and low noise / clean earth tap-offs can be plugged into any socket outlet along the track length. The dual tap-off incorporates both standard and low noise cables.

Optimum layout flexibility is achieved by positioning track lengths a maximum of 5.2 m apart and 2.5 m from the wall, and by connecting the 3 m tap-off units to floor outlet boxes. This means every part of the floor area can be served. Flexible interlinks can be used to overcome obstructions or used as corners if required.

■ Dimensions

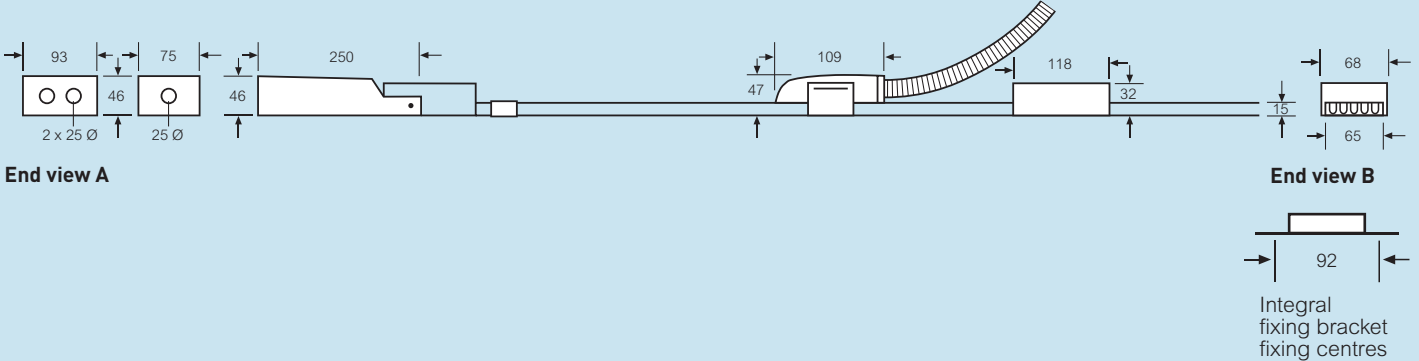

End view A

End view B

■ Example floor layout

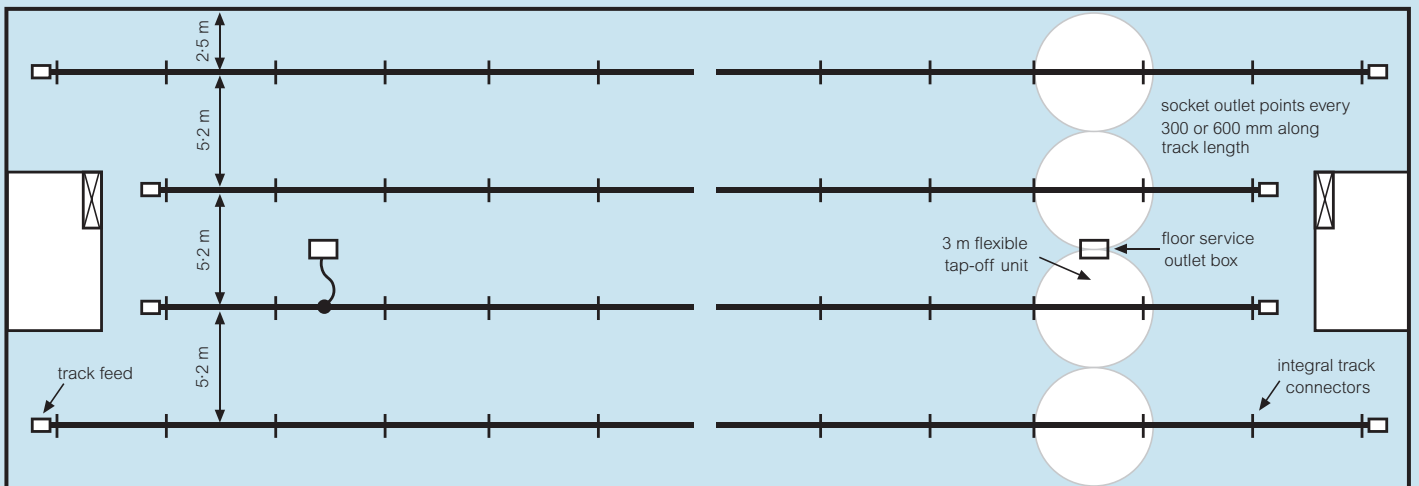

All dimensions (mm) are nominal

■ Special fixing brackets

When installing track off-floor, Electrak special fixing brackets raise track by 21 mm. Ensure brackets are spaced 600 mm apart and always have support under the integral track connector and track feed. Failure to do so may undermine the integrity of the system.

DZ1210 raised off-floor fixing brackets are spaced at 600 mm centres along track. Also use bottom half of bracket under track feed and flexible interlink.

DZ1230 raised off-floor fixing brackets are always used under integral track connectors. Track is secured to raised brackets using the track's integral fixing bracket.

Electrak® power track systems installation

1 Fix track feed to surface

Plug-in key code **TT**

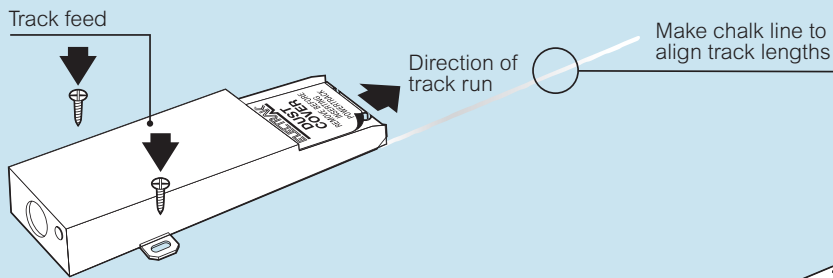

2 Connect track length to track feed

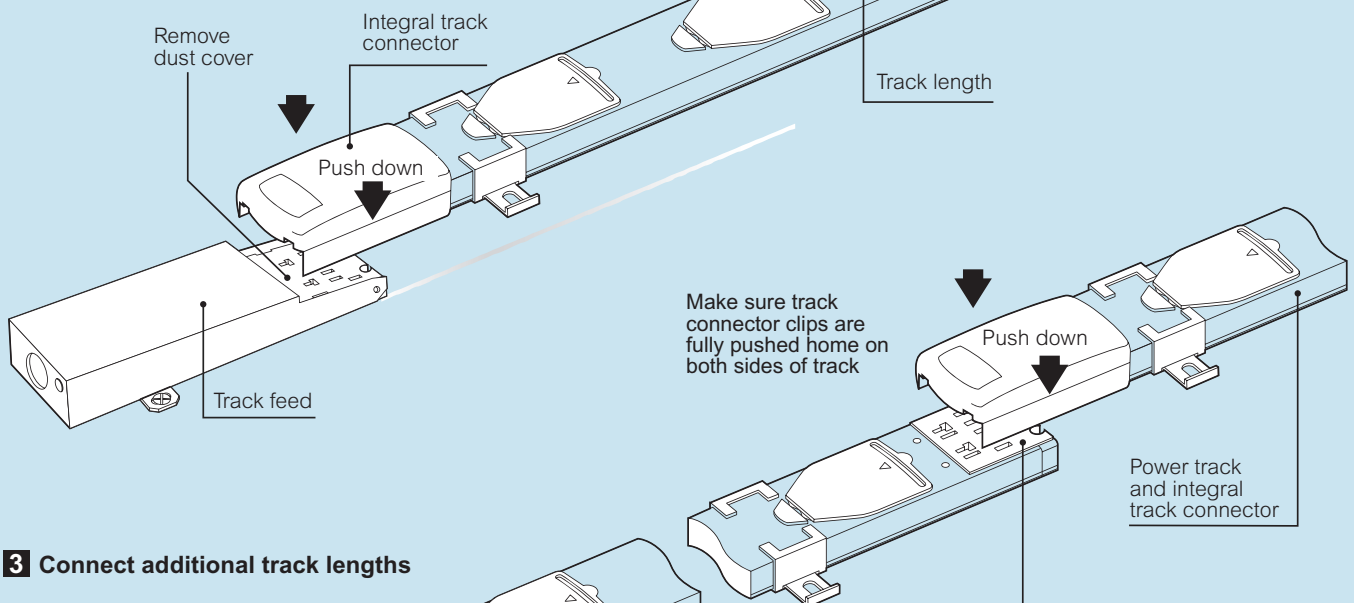

3 Connect additional track lengths

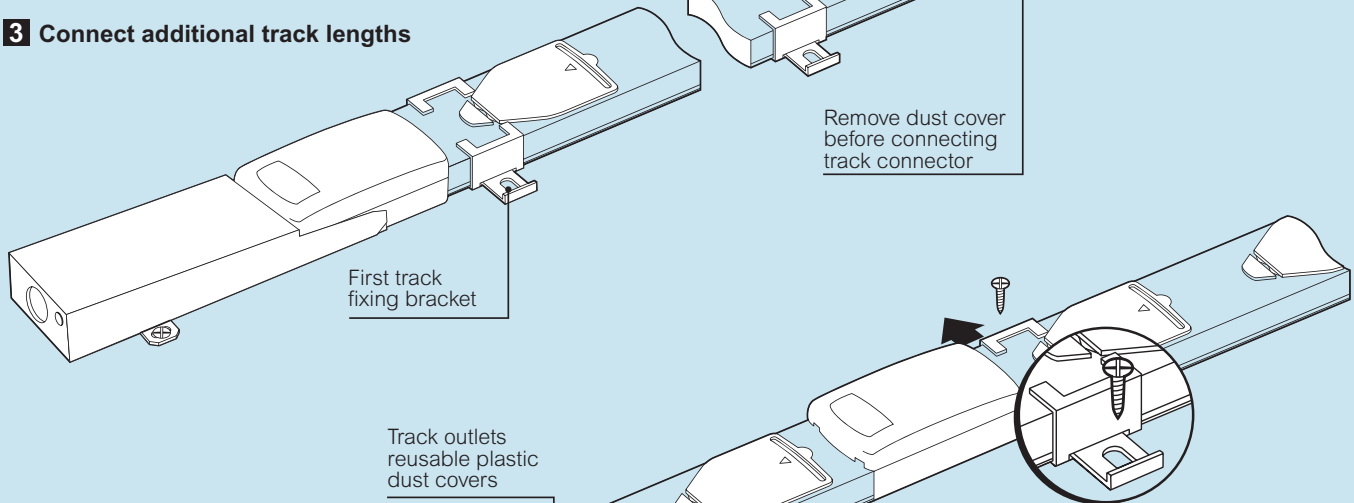

4 Secure track lengths to surface

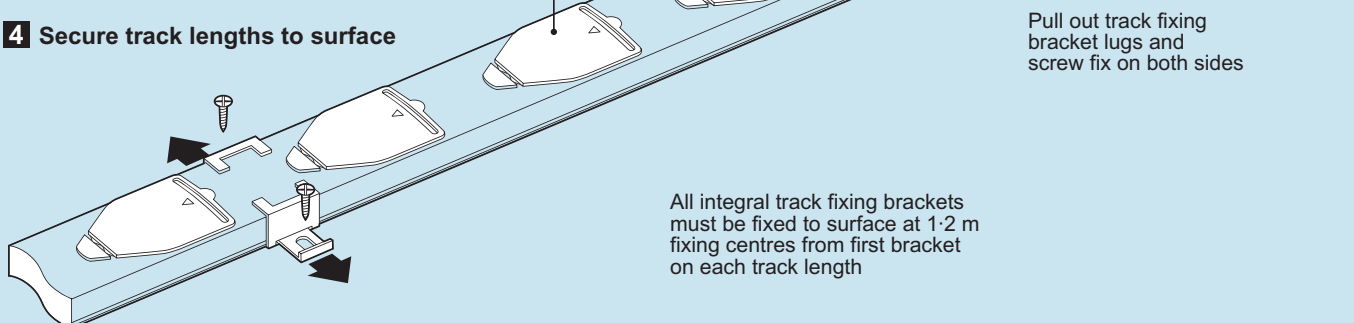

■ Standards

Intertek

Approved to ASTA Standard 138
BS EN 60439-2 : 2000
Manufactured within an approved ISO 9001 : 2008 facility
Assessed Quality Assurance Certificate No. 10679
Electrak fully complies with the requirements of BS 7671 : 2008
(IEE Wiring Regulations)

■ Earth fault loop impedance

BS 7671 : 2008 IEE Wiring Regulations require accurate determination of the total earth loop impedance, which must be sufficiently low to allow the protective device to operate within the specified time, which for socket outlets is 0.4 seconds. The values relevant to Electrak for calculating the earth fault loop impedance are shown in the electrical test data table, see opposite

■ Durability

Electrak systems are superbly designed and extremely robust. They can be expected to stand up to all normal site conditions. Electrak has been short circuit strength tested by ASTA

■ Installations with high protective conductor currents

All unfused tap-offs comply with Regulation 543.7 without the need for additional earth conductors. Regulation 543.7.1.3 (ii) states "a single copper protective conductor having a cross-sectional area of not less than 4 mm², complying with the requirements of Regulations 543.2 and 543.3, the protective conductor being enclosed to provide additional protection against mechanical damage, for example, within a flexible conduit"

For 543.7 installations with high protective conductor currents requiring fused tap-offs, a 543.7 compliant tap-off must be used. Normally fused tap-offs incorporate 1.5 mm² conductors, however in the fused 543.7 tap-offs, the 1.5 mm² earth conductor is replaced with a 4 mm² conductor and therefore complies with Section 543.7.1.3 (ii)

■ 32 A tap-off unit

The 32 A tap-off unit comprises an unfused tap-off with either 2.8 m of 16 mm / 20 mm diameter flexible metal conduit or VO rated nylon conduit both with integral 4 mm² LSOH conductors

These units are designed to comply with regulation 434.2.1 of the IEE Wiring Regulations by virtue of the following :

- maximum length of cable is 3 m
- it is factory assembled and fully tested item with cable installed in high quality flexible conduit

Fault condition protection for the tap-off assembly and the floor box socket outlets is delivered by the circuit protection device
Disconnection time for socket outlets is 0.4 seconds (Regulation 411.3.2.2). The Electrak system meets this requirement

Tap-off units in excess of 3 m should only be used if they contain a fuse or the power track is protected by a 32 A rated protective device

Electrak[®] power track systems

technical data

Electrical test data

Rated current	63 A
Rated voltage	230/400 V~
Frequency	50/60 Hz
Conductor resistance - live and neutral	3.0 mΩ/m
Conductor impedance	1.5 mΩ/m

Volt drops (live and neutral)

Busbars	3.0 mV/A/m
Cable connector	0.4 mV/A
Track connector	0.4 mV/A
32 A tap-off	0.4 mV/A
+ 4 mm ² cable	11 mV/A/m
Flexible corner assembly	1.5 mV/A
+ 10 mm ² cable	4.0 mV/A/m

Earth fault loop impedance

Phase busbar	1.5 mΩ/m
Earth busbar	1.5 mΩ/m
Earth housing	1.1 mΩ/m
Earth busbar and housing	0.8 mΩ/m
Cable connector	0.4 mΩ
Track connector	0.6 mΩ
32 A tap-off	0.6 mΩ
+ 4 mm ² cable	11 mΩ/m
Flexible corner assembly	1.5 mΩ
+ 10 mm ² cable	4.0 mΩ/m
Rated conditional short-circuit current	16 KA
Ambient temperature	25°C

Mechanical data

Number of conductors	3 to 6
Busbar conductor cross sectional area	13 mm ²
Housing cross sectional area (copper equivalent)	13 mm ²
Cable terminal capacity	16 mm ²
Tap-off cable 32 A	4 mm ²
Tap-off cable 13 A fused	1.5 mm ²
Tap-off conduit, up to 4 conductors	16 mmØ
Tap-off conduit, 5 and 6 conductors	20 mmØ
Flexible corner cable (tri-rated, high temperature)	10 mm ²
Flexible corner conduit	25 mmØ
IP rating	40

Material specifications

Power track housing	Galvanised steel, natural finish
Busbars	High conductivity copper
Busbar insulator	PTFE
Track connector/socket outlet/track feed connector	Flame retardant polycarbonate
Socket outlet entry shutter	Acetal
Tap-off housing	Flame retardant polycarbonate
Track connector blades	Copper
Tap-off blades	Copper
Tap-off/flexible corner conduit, metal	Electro-galvanised steel
Tap-off conduit, plastic	VO rated
Tap-off cable	LSOH to BS 7211
Flexible interlink cable	Tri-rated to BS 6231
Track feed box/flexible interlink boxes	Galvanised steel
Track feed connector terminals/earth block	Brass
Track fixing brackets	Galvanised steel
13 A tap-off, fuse	To BS 1362, ASTA approved